

**JANUARY 2018 CSEC MATHEMATICS PAPER 2**  
**SECTION I**

1. (a) Using a calculator, or otherwise, calculate

(i)  $5\frac{1}{2} \div 3\frac{2}{3} + 1\frac{4}{5}$ , giving your answer as a fraction in its lowest terms

**Solution:**

Working out the division:

$$\begin{aligned} 5\frac{1}{2} \div 3\frac{2}{3} &= \frac{(5 \times 2) + 1}{2} \div \frac{(3 \times 3) + 2}{3} \\ &= \frac{11}{2} \div \frac{11}{3} = \frac{11}{2} \times \frac{3}{11} = \frac{3}{2} \end{aligned}$$

$$\begin{aligned} \text{So, } 5\frac{1}{2} \div 3\frac{2}{3} + 1\frac{4}{5} &= \frac{3}{2} + 1\frac{4}{5} = \frac{3}{2} + \frac{9}{5} \\ &= \frac{5(3) + 2(9)}{10} = \frac{15 + 18}{10} = \frac{33}{10} \\ &= 3\frac{3}{10} \text{ as a mixed fraction in its lowest terms} \end{aligned}$$

(ii)  $165 \times 0.38^2$ , giving your answer in EXACT value.

**Solution:**

$$165 \times 0.38^2 = 165 \times 0.38 \times 0.38$$

Using a calculator we get,

$$= 23.826 \text{ (in exact form)}$$

(b) Write your answer in (a) (ii) correct to

(i) two decimal places      (ii) to three significant figures

(iii) to the nearest whole number

**Solution:**

$\begin{array}{r} 23.826 \\ \quad \uparrow \\ + \quad 1 \text{ deciding digit } \geq 5 \\ \hline 23.83 \\ \hline = 23.83 \text{ expressed correct} \\ \text{to 2 decimal places} \end{array}$	$\begin{array}{r} 23.826 \\ \quad \uparrow \\ \text{deciding digit } < 5 \\ = 23.8 \text{ correct to 3} \\ \text{significant figures} \end{array}$	$\begin{array}{r} 23.826 \\ \quad \uparrow \text{ deciding digit } \geq 5 \\ +1 \\ \hline 24 \\ \hline = 24 \text{ expressed to the} \\ \text{nearest whole number} \end{array}$
---	--	--

- (c) Mr. Adams invests \$5 000 at the credit union and received \$5 810, inclusive of simple interest, after 3 years. Determine

- (i) the simple interest earned

**Solution:**

$$\begin{aligned}\text{Simple Interest earned} &= \text{Amount received} - \text{Principal amount} \\ &= \$5\,810 - \$5\,000 = \$810\end{aligned}$$

- (ii) the annual interest rate paid by the credit union

**Solution:**

Let the interest rate be  $R\%$  per annum

$$\text{S.I.} = \frac{P \times R \times T}{100}, \text{ where S.I.} = \text{Interest, } P = \text{Principal}$$

$R = \text{rate } \% \text{ per annum, } T = \text{time in years}$

$$\text{Hence, } 810 = \frac{5\,000 \times R \times 3}{100}$$

$$810 = 150R$$

$$R = \frac{810}{150} \% = 5.4\%$$

- (iii) the length of time it would take for Mr. Adams' investment to be doubled, at the same rate of interest.

**Solution:**

The investment is \$5 000.

Hence for the investment to be doubled, then the interest will have to amount to be \$5 000.

$$\text{Using S.I.} = \frac{P \times R \times T}{100}$$

$$\text{then } 5\,000 = \frac{5\,000 \times 5.4 \times T}{100} \text{ and where } T \text{ is the time taken in years}$$

$$100 = 5.4T$$

$$T = \frac{100}{5.4} \approx 18.518$$

$\approx 18.52$  years (expressed correct to 2 decimal places)

2. (a) Given that  $a * b$  means  $\sqrt{a + 4b}$ , where the positive root is taken, determine

(i) the value of  $1 * 2$

**Solution:**

$$1 * 2 = \sqrt{1 + 4(2)} = \sqrt{1 + 8} = \sqrt{9} = \pm 3$$

$$= 3 \quad (\text{taking the positive root})$$

(ii) whether the operation denoted by  $*$  is commutative. Justify your answer.

**Solution:**

If the operation is to be commutative then  $1 * 2 = 2 * 1$ .

Recall:  $1 * 2 = 3$  (from (a) (i))

So, we calculate  $2 * 1$

$$2 * 1 = \sqrt{2 + 4(1)} = \sqrt{2 + 4} = \sqrt{6} \text{ and which is not equal to } 3.$$

So  $1 * 2 \neq 2 * 1$  and the operation is not commutative.

(b) (i) Solve the inequality  $3 - 2x > 5$ .

**Solution:**

$$3 - 2x > 5$$

$$\text{So} \quad -2x > 5 - 3$$

$$(\times -1) \quad -2x > 2$$

$$(\div 2) \quad 2x < -2$$

$$x < -1$$

OR

if expressed in set builder notation-  $\{x : x < -1\}$

(ii) Represent your answer in (b) (i) on the number line shown below.

**Solution:**

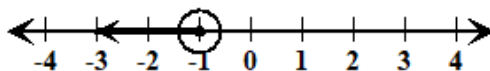

- (c) **Statement one:** Two adult tickets and three children tickets cost \$43.00.  
**Statement two:** One adult ticket and one ticket for a child cost \$18.50.

**Solution:**

- (i) Let  $x$  represent the cost of an adult ticket and  $y$  the cost of a ticket for a child.  
 Write TWO equations in  $x$  and  $y$  to represent the information above.

2 adult tickets at \$ $x$  each and 3 children tickets at \$ $y$  each cost \$43.00

$$\text{Hence, } (2 \times x) + (3 \times y) = 43.00$$

$$2x + 3y = 43.00 \quad \dots \textcircled{1}$$

1 adult ticket at \$ $x$  each and 1 child ticket at \$ $y$  each cost \$18.50

$$\text{Hence, } (1 \times x) + (1 \times y) = 18.50$$

$$x + y = 18.50 \quad \dots \textcircled{2}$$

- (ii) Solve the equations simultaneously to determine the cost of one adult ticket.

**Solution:**

Substitution Method	Elimination Method
$2x + 3y = 43 \quad \dots \textcircled{1}$ $x + y = 18\frac{1}{2} \quad \dots \textcircled{2}$ From equation $\textcircled{2}$ : $y = 18\frac{1}{2} - x \quad \dots \textcircled{3}$ Substitute this expression for $y$ into equation $\textcircled{1}$ to obtain an equation in only $x$ . $2x + 3\left(18\frac{1}{2} - x\right) = 43$ $2x + 55\frac{1}{2} - 3x = 43$ $2x - 3x = 43 - 55\frac{1}{2}$ $-x = -12\frac{1}{2}$ $(\times -1)$ $x = 12\frac{1}{2}$ Hence, one adult ticket costs \$12.50.	$2x + 3y = 43 \quad \dots \textcircled{1}$ $x + y = 18\frac{1}{2} \quad \dots \textcircled{2}$ Equation $\textcircled{2} \times -3$ : $-3x - 3y = -55\frac{1}{2} \quad \dots \textcircled{3}$ Equation $\textcircled{1} + \text{Equation } \textcircled{3}$ : $2x + 3y = 43 \quad \dots(1)$ $\quad \quad \quad +$ $-3x - 3y = -55\frac{1}{2} \quad \dots(2)$ $\hline$ $-x = -12\frac{1}{2}$ $\hline$ $x = 12\frac{1}{2}$ Hence, one adult ticket costs \$12.50.

The equations can also be solved graphically or by the matrix method. These solutions are shown below.

Graphical Method	The matrix method.
<p>We draw the graph of the equation <math>2x + 3y = 43</math> and the equation <math>x + y = 18\frac{1}{2}</math>. The <math>x</math> - coordinate of the point of intersection = 12.5 So, the cost of one adult ticket is \$12.50</p>	<p><math>2x + 3y = 43 \dots \textcircled{1}</math>  <math>x + y = 18\frac{1}{2} \dots \textcircled{2}</math>          The matrix equation is:  <math display="block">\begin{pmatrix} 2 &amp; 3 \\ 1 &amp; 1 \end{pmatrix} \begin{pmatrix} x \\ y \end{pmatrix} = \begin{pmatrix} 43 \\ 18\frac{1}{2} \end{pmatrix}</math>          Let <math>A = \begin{pmatrix} 2 &amp; 3 \\ 1 &amp; 1 \end{pmatrix}</math>, <math>A^{-1} = \begin{pmatrix} -1 &amp; 3 \\ 1 &amp; -2 \end{pmatrix}</math>          Matrix equation <math>\times A^{-1}</math>  <math display="block">A^{-1} \times A \times \begin{pmatrix} x \\ y \end{pmatrix} = \begin{pmatrix} -1 &amp; 3 \\ 1 &amp; -2 \end{pmatrix} \begin{pmatrix} 43 \\ 18\frac{1}{2} \end{pmatrix}</math>  <math display="block">\begin{pmatrix} x \\ y \end{pmatrix} = \begin{pmatrix} 12\frac{1}{2} \\ 6 \end{pmatrix}</math>  <math>x = 12\frac{1}{2}</math></p> <p>The cost of an adult ticket is \$12.50.</p>

3. (a) The Universal set  $U = \{b, d, e, f, g, i, k, s, t, v, w\}$ . The Venn diagram below shows  $U$  and three sets,  $M$ ,  $P$  and  $R$ , which are subsets of  $U$ .

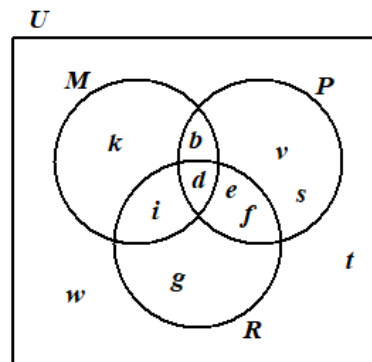

(i) State the value of  $n(P \cup R)$ .

**Solution:**

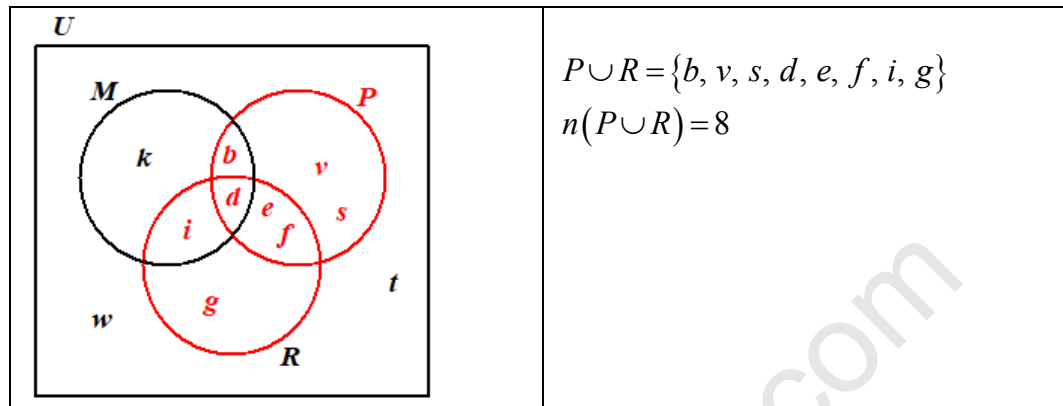

(ii) List the members of a)  $M \cap P$  b)  $M \cup R'$ .

**Solution:**

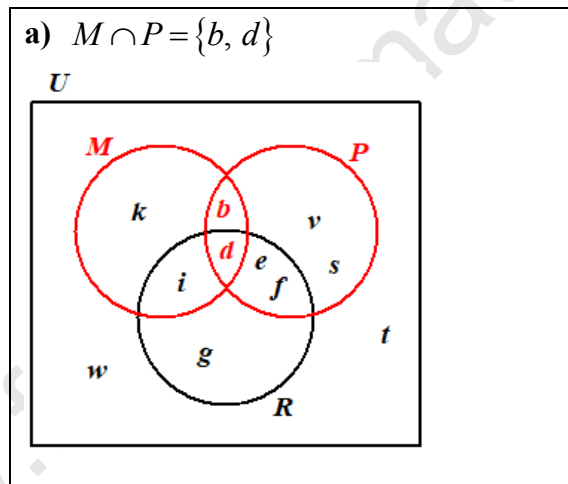

b) First list the sets  $M = \{k, b, i, d\}$  and  $R' = \{k, b, v, s, t, w\}$ .

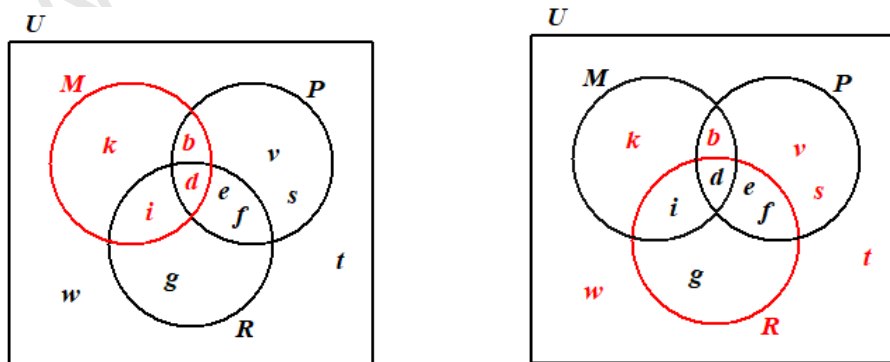

$$\therefore M \cup R' = \{k, b, i, d, v, s, t, w\}$$

- (b) (i) Using a ruler, a pencil and pair of compasses, construct triangle  $PQR$  with  $PQ = 8\text{ cm}$ , angle  $PQR = 120^\circ$  and  $QR = 5\text{ cm}$ .

**Solution:**

Step 1: Construct a line 8 cm long and label it  $PQ$

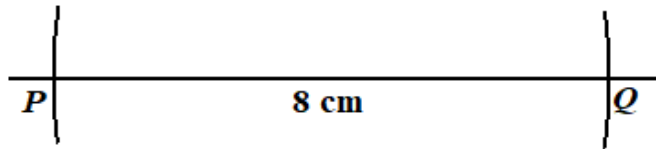

Step 2: Construct an angle of  $120^\circ$  at  $Q$

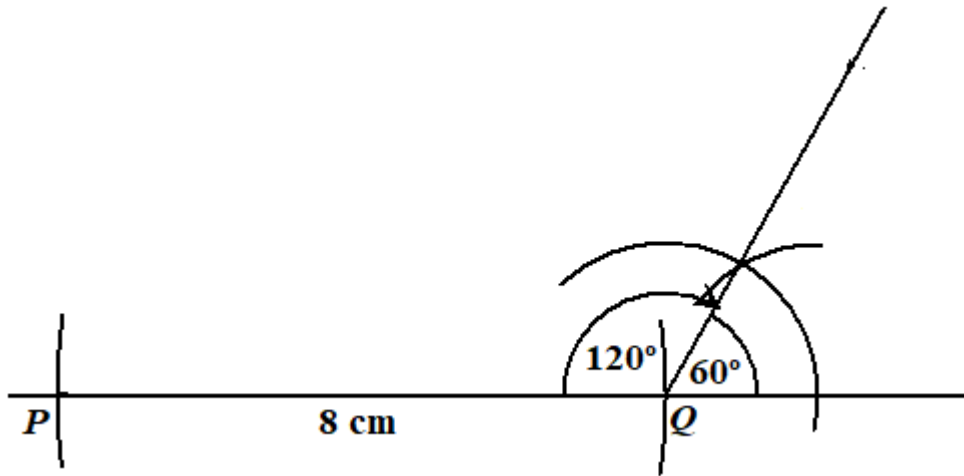

Step 3: Cut off  $QR = 5\text{ cm}$ . Join  $PR$

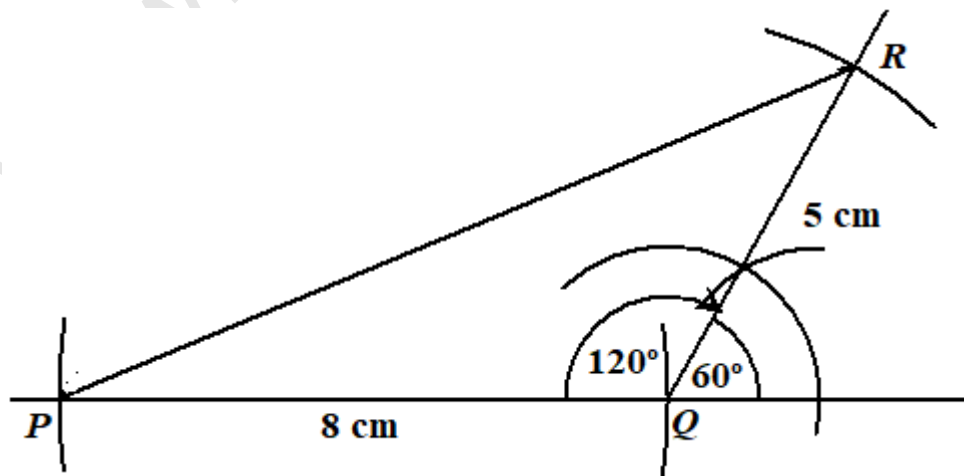

- (ii) Measure and state the length of the side  $PR$ .

**Solution:**

The length of  $PR$  lies between 11.3 cm and 11.4 cm, so we estimate  $PR = 11.35$  cm.

- (iii) On your diagram in (b) (i), construct the point  $S$ , such that  $PQRS$  is a parallelogram.

**Solution:**

Since the opposite sides of a parallelogram are parallel and equal, we construct a  $60^\circ$  at  $P$  and cut off 5 cm to obtain  $S$ .

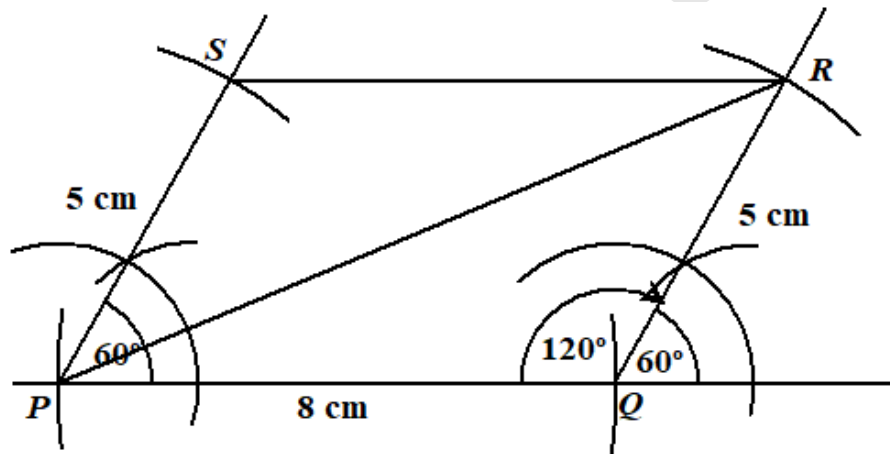

**Alternative Method:**

From  $P$ , draw an arc 5 cm. From  $R$ , draw an arc 8 cm. Since the opposite sides of a parallelogram are equal, the arc cut at  $S$ .

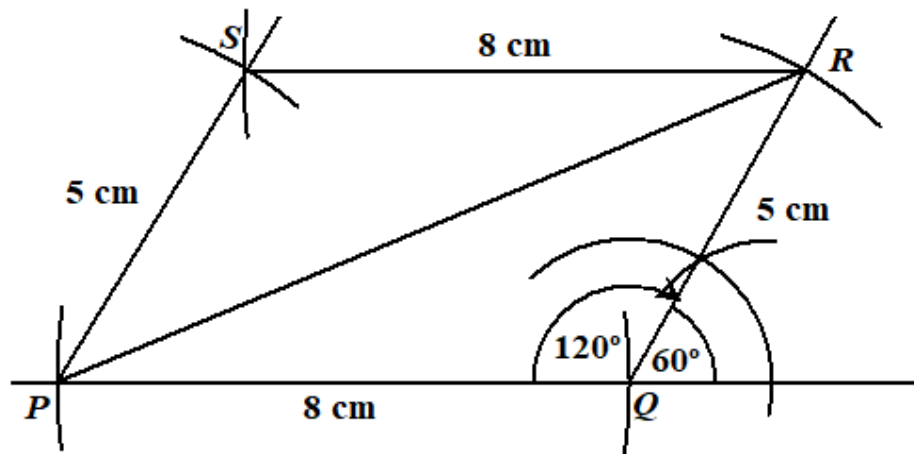



4. (a) The equation of a straight line,  $l$ , is given as  $3x - 4y = 5$ .

(i) Write the equation of the line,  $l$ , in the form  $y = mx + c$ .

**Solution:**

$$3x - 4y = 5$$

$$-4y = -3x + 5 \quad (\div -4)$$

$$y = \frac{-3x}{-4} + \frac{5}{-4}$$

$$y = \frac{3}{4}x - \frac{5}{4} \text{ is of the form } y = mx + c, \text{ where } m = \frac{3}{4} \text{ and } c = -\frac{5}{4}.$$

(ii) Hence, determine the gradient of the line,  $l$ .

**Solution:**

The gradient is the value of  $m$  when the line is expressed in the form,  
 $y = mx + c$

Hence, the gradient of the line,  $l$ , is  $\frac{3}{4}$ .

(iii) The point  $P$  with coordinates  $(r, 2)$  lies on the line  $l$ . Determine the value of  $r$ .

**Solution:**

The point  $P(r, 2)$  lies on the line. Hence, if we were to substitute  $x = r$  and  $y = 2$  the equation of  $l$  must be satisfied.

$$\text{So } 3r - 4(2) = 5$$

$$3r = 5 + 8$$

$$3r = 13 \quad (\div 3)$$

$$r = \frac{13}{3} = 4\frac{1}{3}$$

(iv) Find the equation of the straight line passing through the point  $(6, 0)$  which is perpendicular to  $l$ .

The product of the gradient of perpendicular lines  $= -1$

The gradient of  $l$  is  $\frac{3}{4}$ .

So, the gradient of any line perpendicular to  $l$  is  $\frac{-1}{\frac{3}{4}} = -\frac{4}{3}$ .

The required line passes through the point with coordinates  $(6, 0)$  and is perpendicular to  $l$ .

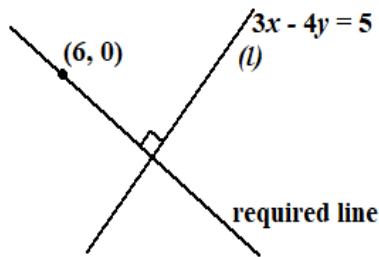

The equation of the required line is

$$\frac{y-0}{x-6} = -\frac{4}{3}$$

$$y-0 = -\frac{4}{3}(x-6)$$

$$y = -\frac{4}{3}x + 8$$

or any other equivalent form such as  $3y = -4x + 24$  OR  $3y + 4x - 24 = 0$ .

- (b) (i) Draw the straight lines  $x + y = 10$  and  $y = x$  on the grid below.

**Solution:**

To draw a straight line, we require the coordinates of only two points on the line. For each of the lines, it is convenient to choose  $x = 0$  and find the corresponding value of  $y$  and then  $y = 0$  and find the corresponding value of  $x$ .

For  $x + y = 10$

$y$	$x$
0	10
10	0

For  $y = x$

$y$	$x$
0	0
10	10

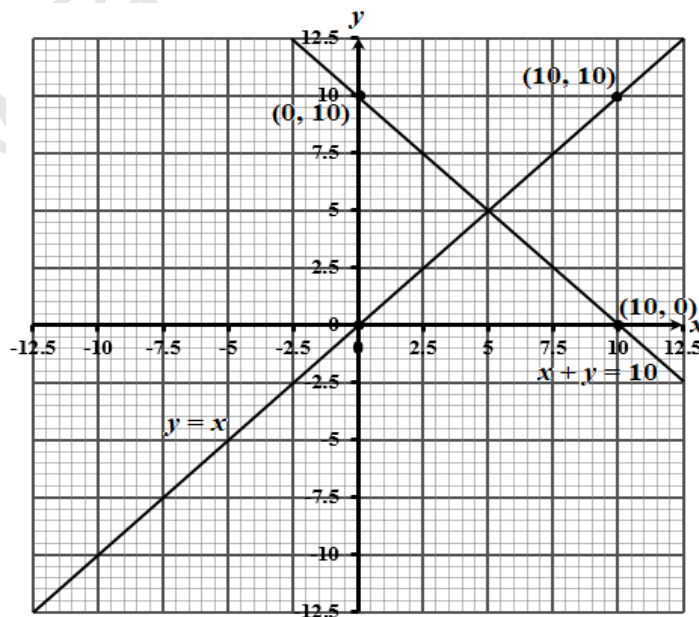

- (ii) On the same grid, shade the region which satisfies the FOUR inequalities.  
 $x \geq 0$ ,  $y \geq 0$ ,  $x + y \leq 10$  and  $x \geq y$   
 Showing each region separately

$x = 0$  is the equation of the  $y$  – axis.  
 The shaded region represents  $x \geq 0$  .

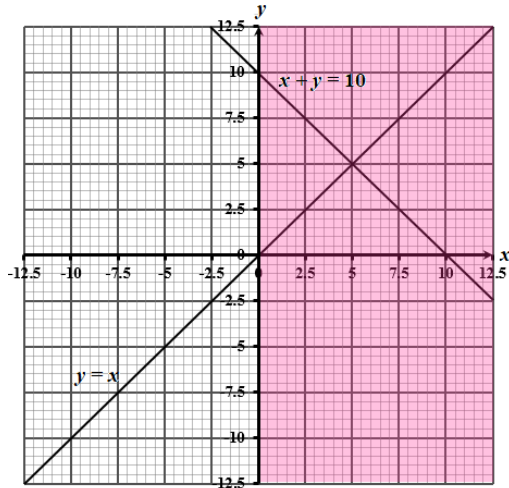

$y = 0$  is the equation of the  $x$  – axis. The shaded region represents  $y \geq 0$ .

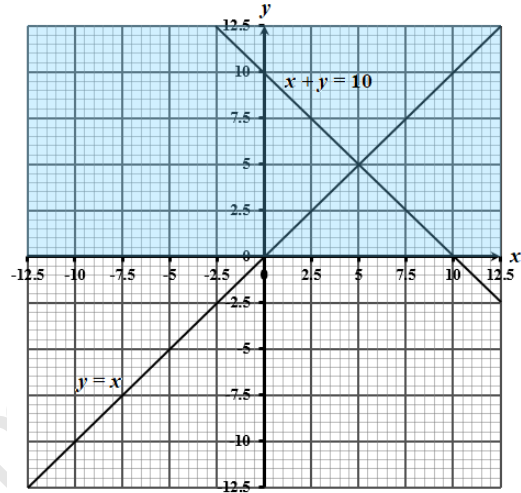

The shaded region represents  $x + y \leq 10$ .

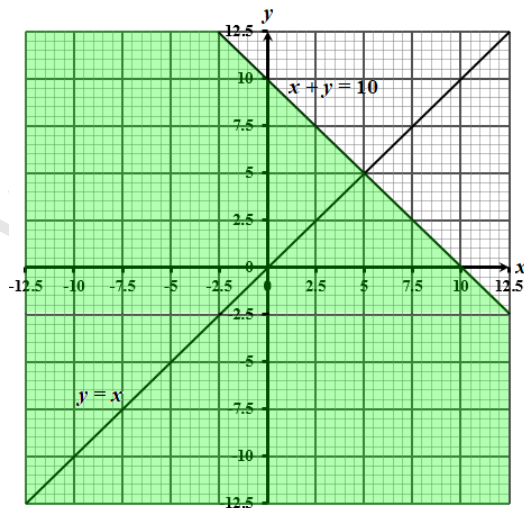

The shaded region represents  $x \geq y$  or  $y \leq x$ .

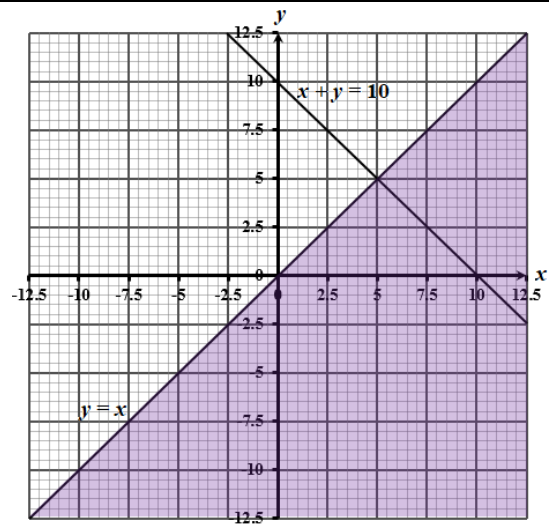

On the same diagram, the region common to all four inequalities is:

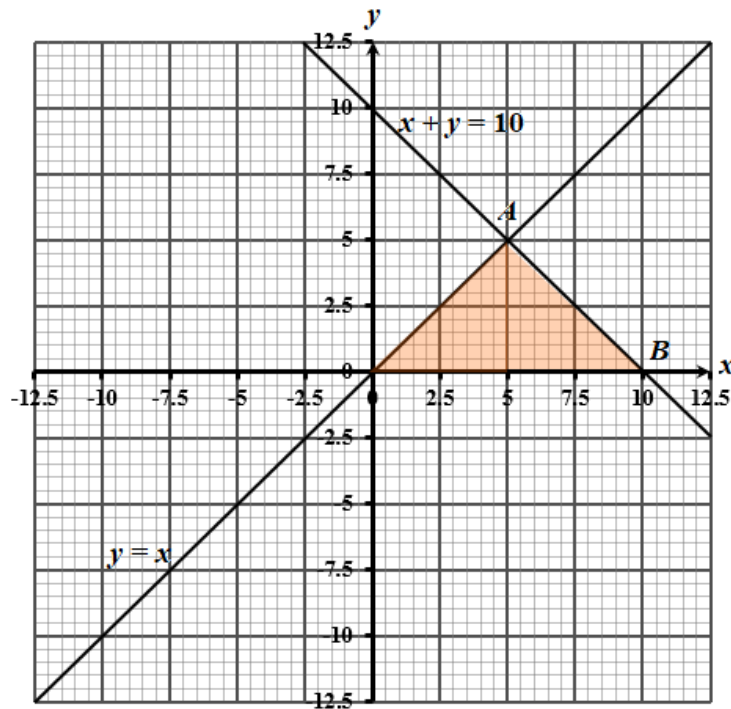

The region  $OAB$  represents  $x \geq 0$ ,  $y \geq 0$ ,  $x + y \leq 10$  and  $x \geq y$  and is called the feasible region.

5. (a) The regular polygon  $EFGHIJ$ , shown below, has center,  $O$ . Triangle  $OEF$  is equilateral and  $EF = 5$  cm.

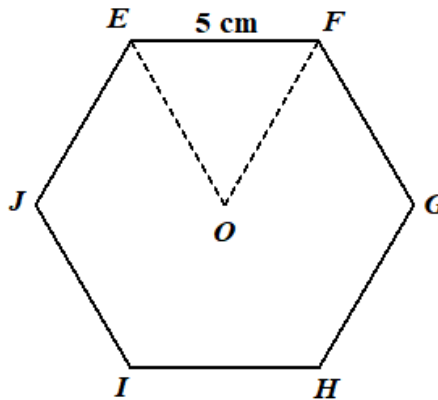

- (i) What is the name of the polygon shown above?

**Solution:**

The polygon has 6 sides and is hence a hexagon. Since all the sides are equal, it is a regular hexagon.

- (ii) Calculate the perimeter of the polygon  $EFGHIJ$ .

**Solution:**

Since each of the sides are equal and are 5 cm each, the perimeter of  $EFGHIJ = 5 \text{ cm} \times 6$   
 $= 30 \text{ cm}$

- (iii) Determine the size of each interior angle of the polygon.

**Solution:**

The sum of the interior angles of a polygon of  $n$  sides  
 $= (2n - 4) \times 90^\circ$  **OR**  $2(n - 2) \times 180^\circ$

Hence, the sum of the 6 interior angles of the given hexagon is  
 $= \{2(6) - 4\} \times 90^\circ = 720^\circ$  **OR**  $= \{2(4 - 2)\} \times 180^\circ = 720^\circ$

Each interior angle of a regular polygon is equal.

Hence, each interior angle of the regular hexagon  $= \frac{720^\circ}{6} = 120^\circ$

- (iv) Show, by calculation, that the area of the polygon, to the nearest whole number, is  $65 \text{ cm}^2$ .

**Solution:**

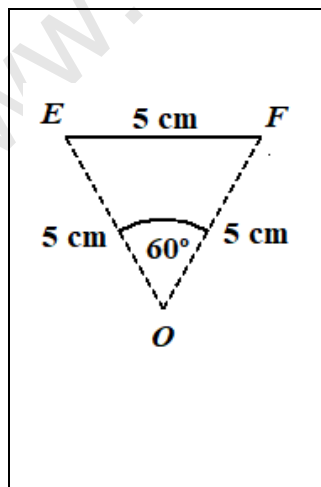

Using the area of a triangle

$$= \frac{1}{2} (\text{side} \times \text{side}) \times \sin (\text{the included angle})$$

$$\text{The area of } \triangle OEF = \frac{1}{2} (5)(5) \sin 60^\circ$$

The hexagon can be regarded as consisting of 6 of these triangles.

So the area of the given regular hexagon

$$= \left\{ \frac{1}{2} (5)(5) \sin 60^\circ \right\} \times 6$$

$$= \underline{64.95} \text{ cm}^2 \approx 65 \text{ cm}^2 \text{ to the nearest whole number.}$$

**Q.E.D**

- (b) A tank has a cross section with dimensions identical to the polygon  $EFGHIJ$  in 5 (a) Water is poured into the tank at a rate of  $75 \text{ cm}^3$  per second. After 52 seconds the tank is  $\frac{2}{5}$  full.

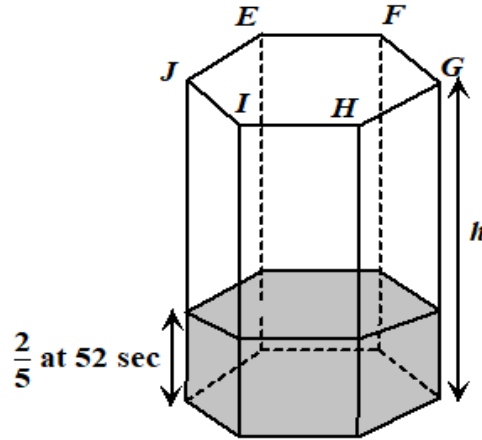

- (i) Determine the capacity of the tank, in litres.

**Solution:**

The hexagonal area of the base of the tank =  $64.95 \text{ cm}^2$

Water is poured at a constant rate of  $75 \text{ cm}^3\text{s}^{-1}$ .

Hence, after 52 seconds, the volume of water poured

$$= 75 \times 52 \text{ cm}^3 = 3\,900 \text{ cm}^3$$

The tank is  $\frac{2}{5}$  full. Hence,  $\frac{2}{5}$  of the capacity,  $V \text{ cm}^3 = 3\,900 \text{ cm}^3$

$$\therefore \frac{2}{5}V = 3\,900 \text{ cm}^3$$

$$V = \frac{3\,900 \times 5}{2} \text{ cm}^3 = \frac{3\,900 \times 5}{2 \times 1\,000} \text{ l} = 9.75 \text{ litres}$$

- (ii) Calculate, the height,  $h$ , in metres, of the tank.

**Solution:**

If the height of the tank is  $h \text{ cm}$ , then

$$\frac{2}{5}h \times \text{area of the base} = 3\,900 \text{ cm}^3$$

$$\frac{2}{5} \times h \times 64.95 = 3\,900$$

$$h = \frac{3\,900 \times 5}{2 \times 64.95} \text{ cm} = \frac{3\,900 \times 5}{2 \times 64.95 \times 100} \text{ m} = 1.501 \text{ m} \\ = 1.50 \text{ m (correct to 2 decimal places)}$$

6. The diagram below shows triangle  $PQR$ .

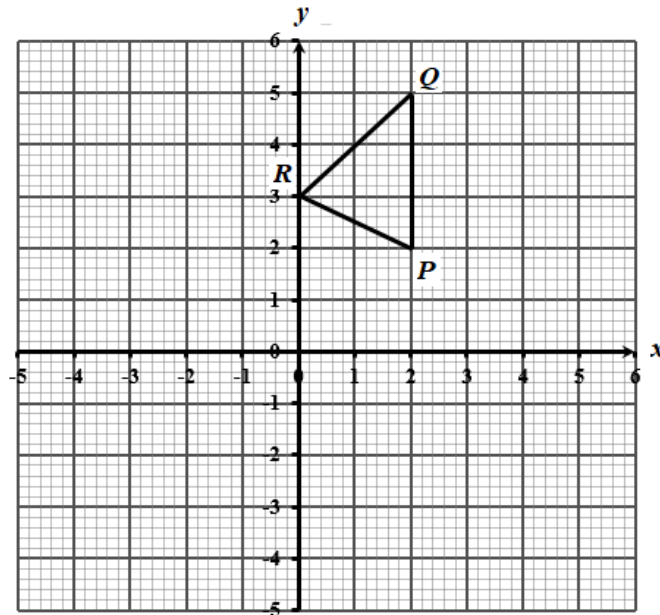

- (a) State the coordinates of  $R$ .

From the diagram,  $R$  has coordinates  $(0, 3)$  obtained by a read off.

- (b) On the diagram above, draw

- (i)  $\Delta P'Q'R'$ , a reflection of  $\Delta PQR$  in the line  $y = 1$ .

**Solution:**

The line with equation  $y = 1$  is a horizontal line that cuts the vertical axis at  $y = 1$ .

We check the number of units that  $P$ ,  $Q$ , and  $R$  are from this reflection line and count the corresponding number of units on the opposite side of the line to obtain the images for each as,  $P'$ ,  $Q'$  and  $R'$ .

Now we draw the  $\Delta P'Q'R'$  as shown.

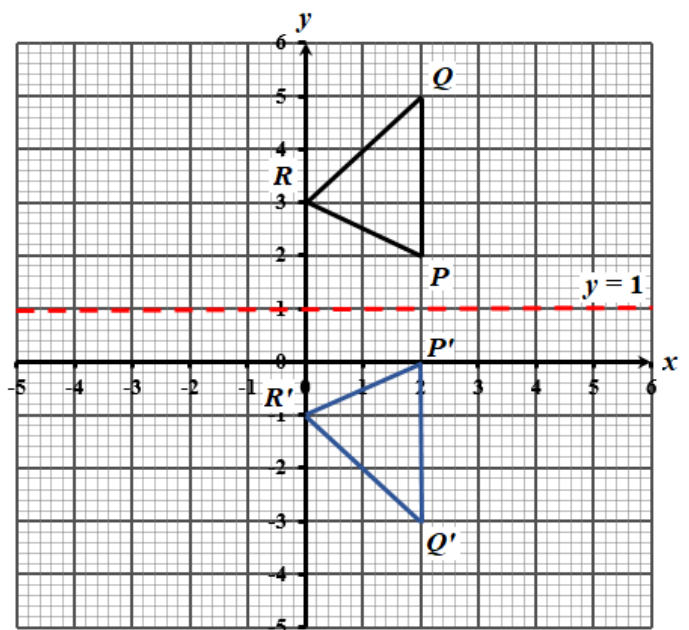

- (ii)  $\Delta P''Q''R''$ , the reflection of  $\Delta P'Q'R'$  in the line  $x = 0$ .

**Solution:**

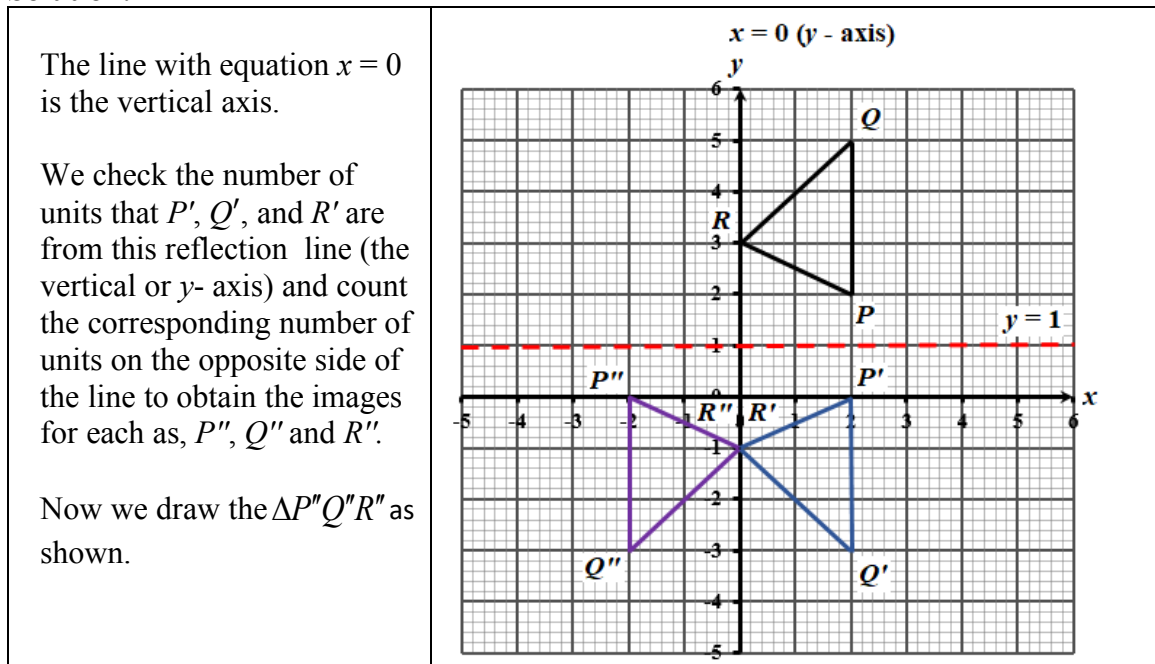

- (c) Describe, fully, that single transformation that maps  $\Delta P''Q''R''$  onto  $\Delta PQR$ .

**Solution:**

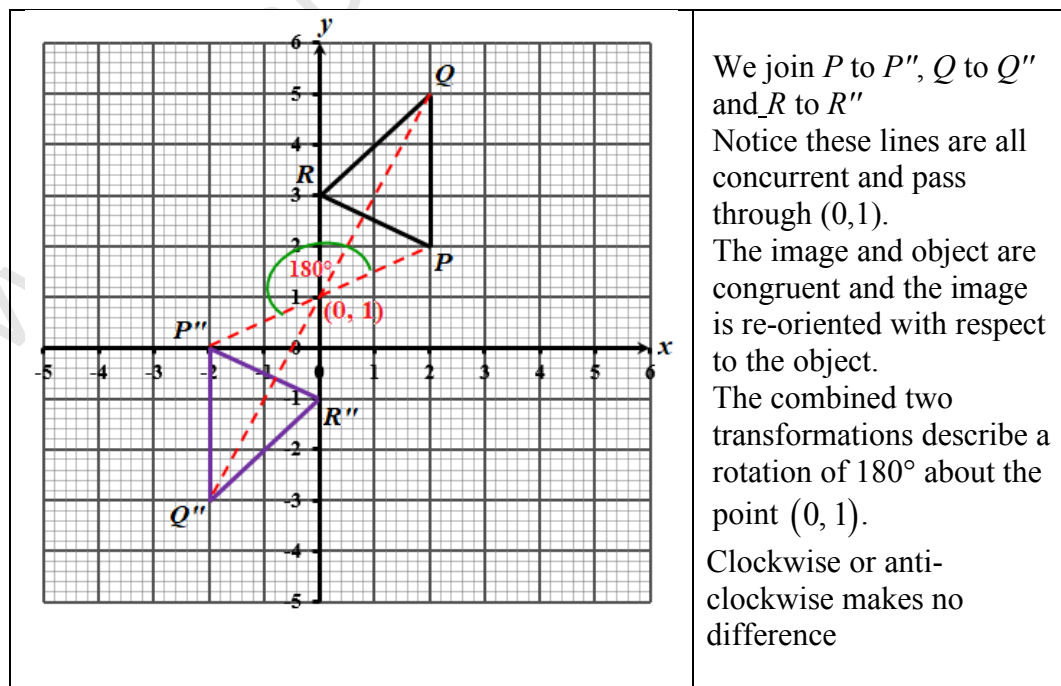



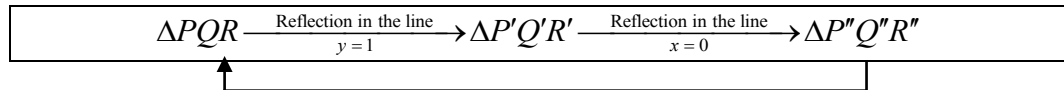

- (d) Triangle  $PQR$  undergoes an enlargement of scale factor 2. Calculate the area of its image.

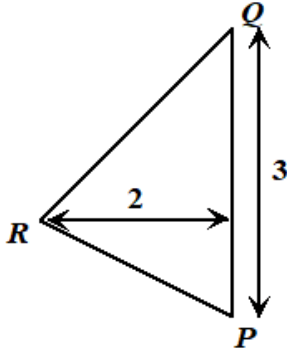
<p>Let us consider <math>\Delta PQR</math>:</p> 	<p>Area = <math>\frac{3 \times 2}{2}</math> square units = 3 square units</p> <p><math>\Delta PQR \xrightarrow{\text{Enlarged by scale factor 2}}</math></p> <p>Hence, the area of the enlarged triangle = 3 square units <math>\times</math> (scale factor)<sup>2</sup></p> <p>= <math>3 \times (2)^2</math> square units = 12 square units</p>
---	--

7. (a) The marks obtained by 10 students in a test, scored out of 60, are shown below.

29    38    26    42    38

45    35    37    38    31

For the data above, determine

- (i) the range

**Solution:**

The highest mark is 45. The lowest mark is 26.

The range of the data is the difference between the highest and lowest values in a distribution.

So, the range =  $45 - 26 = 19$

- (ii) the median

**Solution:**

Arranging the data in ascending order of magnitude:

There is an even number of scores.

37 and 38 are the two middle scores. So, the median will be the mean of these two scores.

26 29 31 35 37 38 38 38 42 45

↑

$$\text{Median} = \frac{37+38}{2} = 37.5$$

(iii) the interquartile range

**Solution:**

Since neither 37 nor 38 were part of the median value, they will be counted when finding the lower quartile and upper quartile.

26 29 31 35 37 38 38 38 42 45

↑

↑

↑

Lower quartile

Median

Upper quartile

$$Q_1 = 31$$

$$Q_3 = 38$$

The middle value from 26 to 37

The middle value from 38 to 45

$$\begin{aligned} \text{The interquartile range (I.Q.R.)} &= \text{Upper quartile, } Q_3 - \text{Lower quartile, } Q_1 \\ &= 38 - 31 = 7 \end{aligned}$$

(iv) The probability that a student chosen at random scores less than half the total marks in the test.

**Solution:**

The total marks in the test = 60

P(Student scores less than half the total)

$$= \frac{\text{No. of students who scored less than 30}}{\text{Total no. of students}} = \frac{2}{10} = \frac{1}{5} \text{ or } 0.2 \text{ or } 20\%$$

(b) The frequency distribution below shows the masses, in kg, of 50 adults prior to the start of a fitness programme.

Mass (kg)	Midpoint	Frequency
60 – 64	62	8
65 – 69	67	11
70 – 74	72	15
75 – 79	77	9
80 – 84	82	5
85 – 89	87	2

On the grid, using a scale of 2 cm to represent 5 units on the  $x$  – axis and 1 cm to represent 1 unit on the  $y$  – axis, draw a frequency polygon to represent the information on the table.

**Solution:**

The points to be plotted for a frequency polygon will have as coordinates (midpoint or mid-class interval, frequency). Hence the points to be plotted for the above distribution will be  $(57, 0)$ ,

$(62, 8)$ ,  $(67, 11)$ ,  $(72, 15)$ ,  $(77, 9)$ ,  $(82, 5)$ ,  $(87, 2)$ ,  $(92, 0)$ .

The first and last points (written in red) are plotted so as to complete the frequency polygon and so that it starts and ends on the horizontal axis.

www.faspasmaths.com

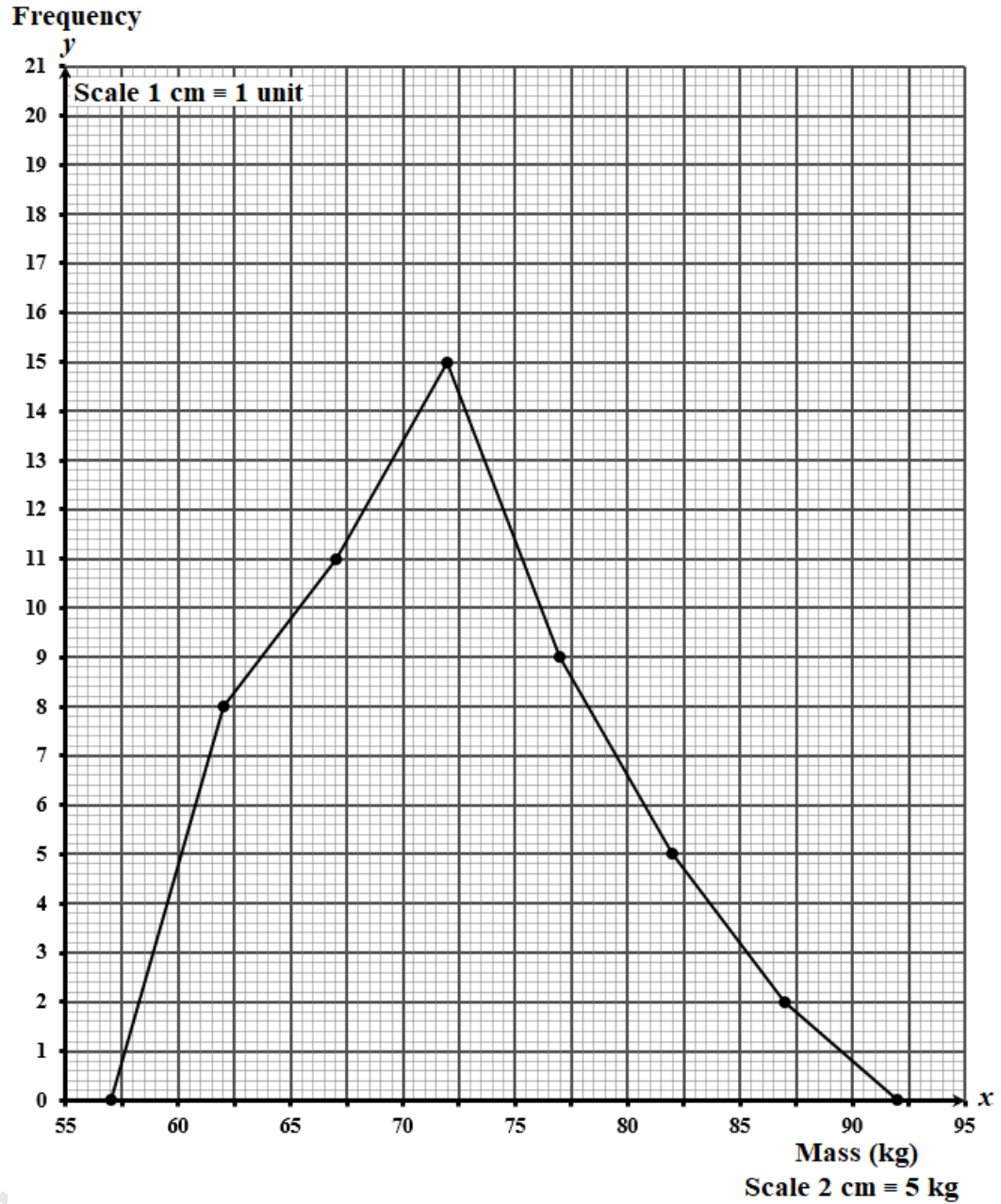

8. A sequence of figures is made from toothpicks of unit length. The first three figures in the sequence are shown below.



Figure 1



Figure 2



Figure 3

- (a) Draw Figure 4 of the sequence.

**Solution:**

Figure 1 has 1 triangle, Figure 2 has 3 triangles, and Figure 3 has 5 triangles. Since the numbers of triangles in successive figures increase by 2, we would expect that the fourth figure will have  $5 + 2 = 7$  triangles. This is shown below.



- (b) Study the patterns of numbers in each row of the table below. Each row relates to one of the figures in the sequence of figures below. Some rows have not been included in the table.

Complete the rows numbers (i), (ii), (iii) and (iv).

Figure	Number of Toothpicks in Pattern	Perimeter of Figure
1	3	$0 + 1 + 2 = 3$
2	7	$1 + 2 + 2 = 5$
3	11	$2 + 3 + 2 = 7$
(i) 4		
(ii)		$19 + 20 + 2 = 41$
(iii)	127	
(iv) $n$		

**Solution:**

Consider the figure  $n$  and the number of toothpicks which we call  $t$ .

Figure, $n$	No. of Toothpicks, $t$
1	3
2	7
3	11

We may choose any of the following methods to obtain an expression for  $t$ .

$n \rightarrow t$ $1 \rightarrow 3$ $2 \rightarrow 3 + 4 = 7$ $3 \rightarrow 3 + 4 + 4 = 11$ To continue the pattern, $4 \rightarrow 3 + 4 + 4 + 4 = 15$  Notice that the number of 4's is one less than the figure number, $n$ .  $n \rightarrow 3 + (n - 1) \times 4$ $n \rightarrow 3 + 4n - 4$ $t = 4n - 1$	Notice that for each successive figure, the value of $t$ increases by 4. $t = 4n + k$ , where $k$ is a constant  When $n = 1, t = 3$ $3 = 4(1) + k$ $k = 3 - 4 = -1$ We test with $n = 2$ . $t = (4 \times 2) - 1 = 7$ (true)  When $n = 3$ $t = (4 \times 3) - 1 = 11$ (true)  So, $t = 4n - 1$
--	--

Consider the figure  $n$  and the perimeter which we call  $P$ .

Figure, $n$	Perimeter of Figure, $P$
1	3
2	5
3	7

We may choose any of the following methods to obtain an expression for  $P$ .

$n \rightarrow P$ $1 \rightarrow 3$ $2 \rightarrow 3 + 2 = 5$ $3 \rightarrow 3 + 2 + 2 = 7$ To continue the pattern, $4 \rightarrow 3 + 2 + 2 + 2 = 9$ Notice that the number of 2's is one less than the figure number, $n$ .  $n \rightarrow 3 + (n - 1) \times 2$ $n \rightarrow 3 + 2n - 2$ $P = 2n + 1$	Notice that for each successive figure, the perimeter increases by 2. $P = 2n + l$ , where $l$ is a constant When $n = 1, P = 3 \therefore P = (2 \times 1) + 1$ $3 = 2(1) + l, l = 3 - 2 = 1$ Test with $n = 2$ . $P = (2 \times 2) + 1 = 5$ (true)  When $n = 3, P = (2 \times 3) + 1 = 7$ $\therefore P = 2n + 1$
--	--

We are now in a position to complete the table:

<b>(i)</b> When $n = 4$ $t = 4n - 1 = 4(4) - 1 = 15$ $P = 2n + 1 = 2(4) + 1 = 9$	<b>(ii)</b> When $P = 41$ $\therefore 2n + 1 = 41$ $2n = 41 - 1 = 40 \quad (\div 2)$ $n = 20$ When $n = 20, t = 4(20) - 1 = 79$
--	---

<p><b>(iii)</b> When <math>t = 127</math>  <math>\therefore 4n - 1 = 127</math>  <math>4n = 127 + 1 = 128 \quad (\div 4)</math>  <math>n = 32</math>                  When <math>n = 32</math>  <math>P = 2(32) + 1 = 64 + 1 = 65</math></p>	<p><b>(iv)</b> <math>t = 4n - 1</math> and <math>P = 2n + 1</math></p>
--	--

The completed table looks like:

	Figure	Number of Toothpicks in Pattern	Perimeter of Figure
	1	3	$0 + 1 + 2 = 3$
	2	7	$1 + 2 + 2 = 5$
	3	11	$2 + 3 + 2 = 7$
<b>(i)</b>	4	15	$3 + 4 + 2 = 9$
<b>(ii)</b>	20	79	$19 + 20 + 2 = 41$
<b>(iii)</b>	32	127	$2(32) + 1 = 65$
<b>(iv)</b>	$n$	$4n - 1$	$2n + 1$

SECTION II

Answer TWO questions in this section.

ALGEBRA AND RELATIONS, FUNCTIONS AND GRAPHS

9. (a) (i) Show, by calculation, that the EXACT roots of the quadratic equation  $x^2 + 2x - 5 = 0$  are  $-1 \pm \sqrt{6}$ .

**Solution:**

$x^2 + 2x - 5 = 0$  is of the form  $ax^2 + bx + c = 0$ , where  $a = 1$ ,  $b = 2$  and  $c = -5$ . When a quadratic is expressed in this form then:

$$\begin{aligned} x &= \frac{-b \pm \sqrt{b^2 - 4ac}}{2a} = \frac{-(2) \pm \sqrt{(2)^2 - 4(1)(-5)}}{2(1)} = \frac{-2 \pm \sqrt{4 + 20}}{2} \\ &= \frac{-2 \pm \sqrt{24}}{2} = \frac{-2 \pm \sqrt{4 \times 6}}{2} = \frac{-2 \pm \sqrt{4} \sqrt{6}}{2} \\ &= \frac{-2 \pm 2\sqrt{6}}{2} = \frac{-2 + 2\sqrt{6}}{2} \text{ or } \frac{-2 - 2\sqrt{6}}{2} \\ &= -1 + \sqrt{6} \text{ or } -1 - \sqrt{6} = -1 \pm \sqrt{6} \end{aligned}$$

- (ii) Hence, or otherwise, solve the simultaneous equations:  $2 + x = y$   
 $xy = 5$

**Solution:**

$$\begin{aligned} \text{Let } 2 + x &= y && \dots \text{ ①} \\ \text{and } xy &= 5 && \dots \text{ ②} \end{aligned}$$

Substitute  $y = 2 + x$  into equation ②:

$$x(2 + x) = 5$$

$$2x + x^2 = 5$$

$$x^2 + 2x - 5 = 0$$

This is the same equation as seen in part (i) above. Hence,

$$x = -1 \pm \sqrt{6}$$

$$x = -1 + \sqrt{6} \text{ or } -1 - \sqrt{6}$$

$$\text{When } x = -1 + \sqrt{6} \quad y = 2 + (-1 + \sqrt{6}) = 2 - 1 + \sqrt{6} = 1 + \sqrt{6}$$

$$\text{When } x = -1 - \sqrt{6} \quad y = 2 + (-1 - \sqrt{6}) = 2 - 1 - \sqrt{6} = 1 - \sqrt{6}$$

Hence,  $x = -1 + \sqrt{6}$  and  $1 + \sqrt{6}$

**OR**  $x = -1 - \sqrt{6}$  and  $y = 1 - \sqrt{6}$ .



- (b) The incomplete table below shows the values of  $x$  and  $y$  for the function  $y = 2^x$  for integer values of  $x$  from  $-1$  to  $4$ .

$x$	$-1$	$0$	$1$	$2$	$3$	$4$
$y$		$1$			$8$	

- (i) Complete the table for the function  $y = 2^x$ .

**Solution:**

When  $x = -1, y = 2^{-1} = \frac{1}{2^1} = \frac{1}{2}$

When  $x = 1, y = 2^1 = 2$

When  $x = 2, y = 2^2 = 4$

When  $x = 4, y = 2^4 = 16$

$x$	$-1$	$0$	$1$	$2$	$3$	$4$
$y$	$\frac{1}{2}$	$1$	$2$	$4$	$8$	$16$

- (ii) On the grid provided, draw the graph of  $y = 2^x$ , using a scale of  $2$  cm to represent  $1$  unit on the  $x$ -axis and  $1$  cm to represent  $1$  unit on the  $y$ -axis.

**Solution:**

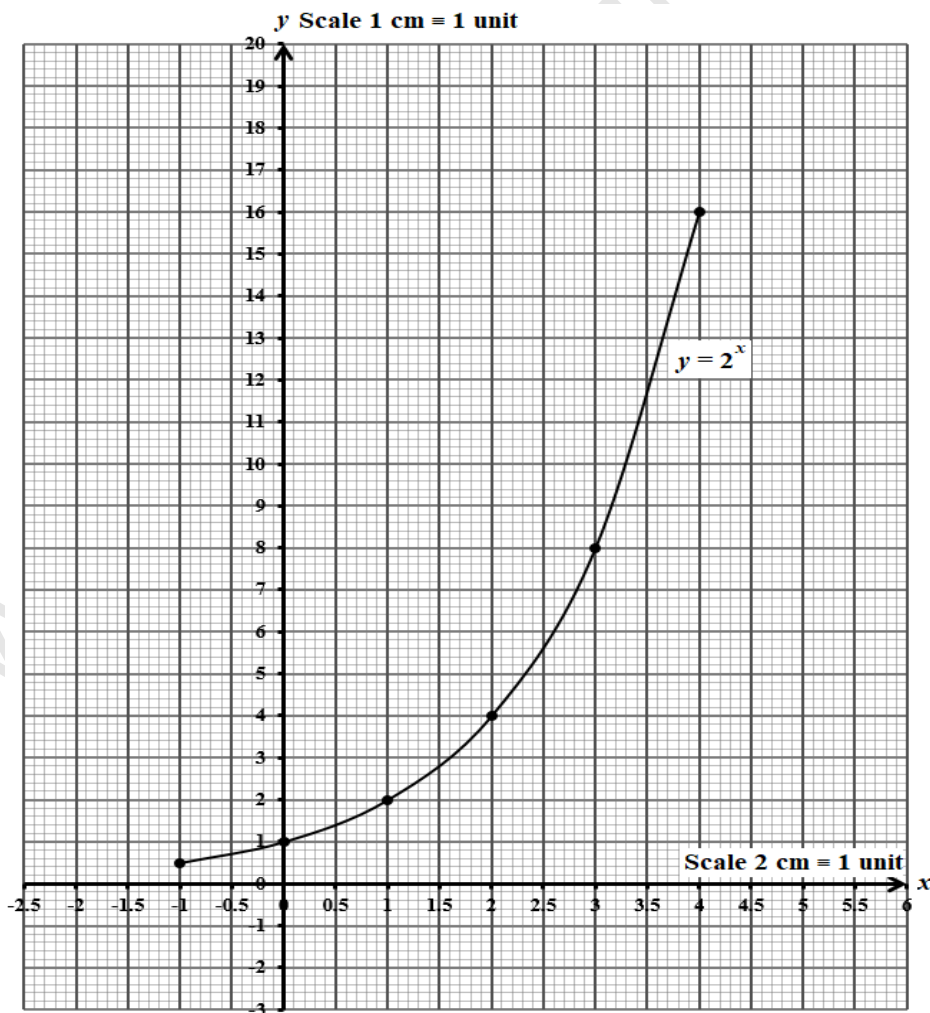

- (iii) Drawing appropriate lines on your graph, determine the value of  $x$  for which  $2^x = 11$ .

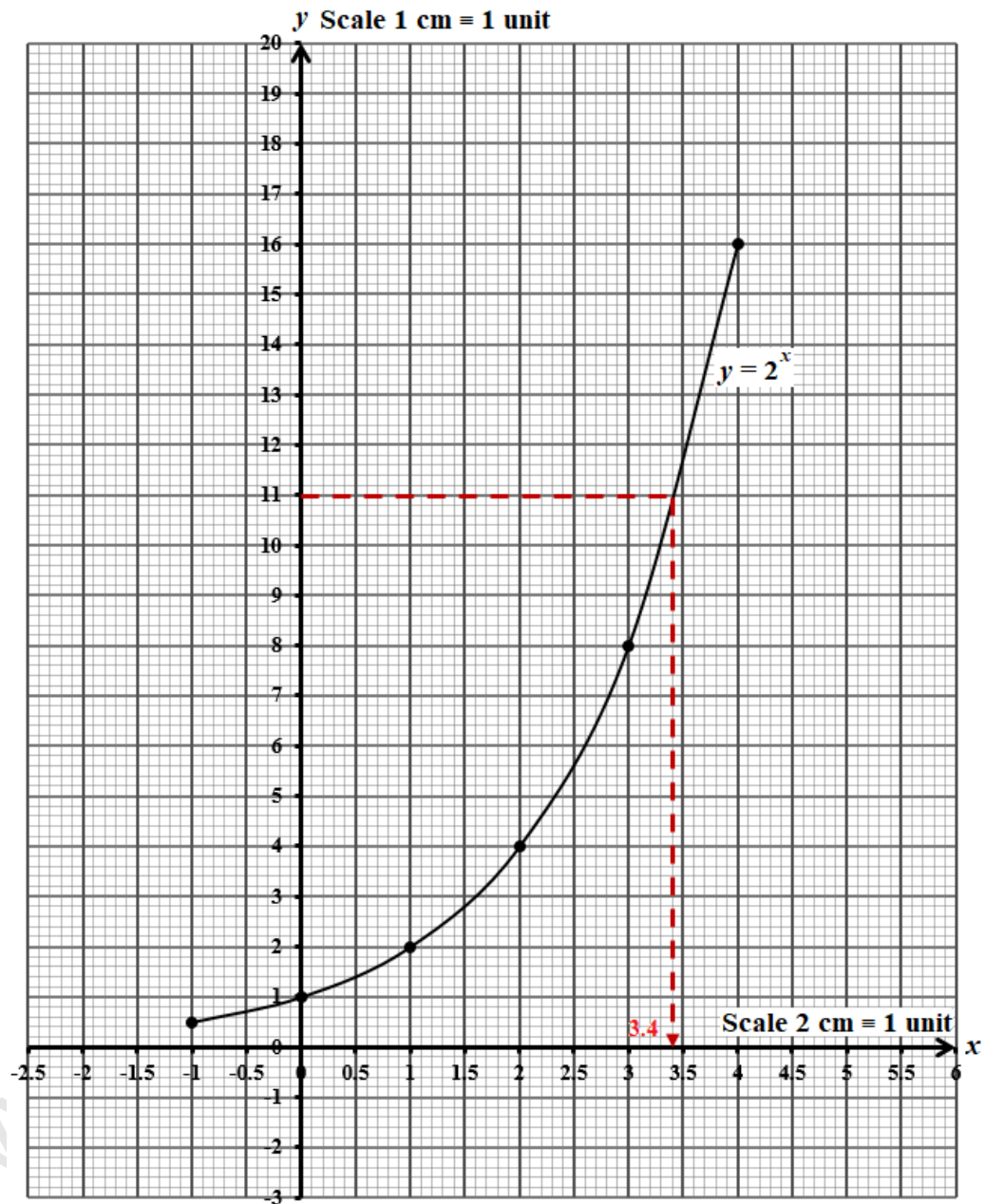

When  $2^x = 11$ , then  $x = 3.4$  (by read off)

MEASUREMENT, GEOMETRY AND TRIGONOMETRY

10. (a) The diagram below, **not drawn to scale**, shows a circle with center  $O$ . The points  $A, B, C$  and  $D$  are on the circumference of the circle,  $EAF$  and  $EDG$  are tangents to the circle at  $A$  and  $B$  respectively.  $\hat{AOD} = 114^\circ$  and  $\hat{CDG} = 18^\circ$ .

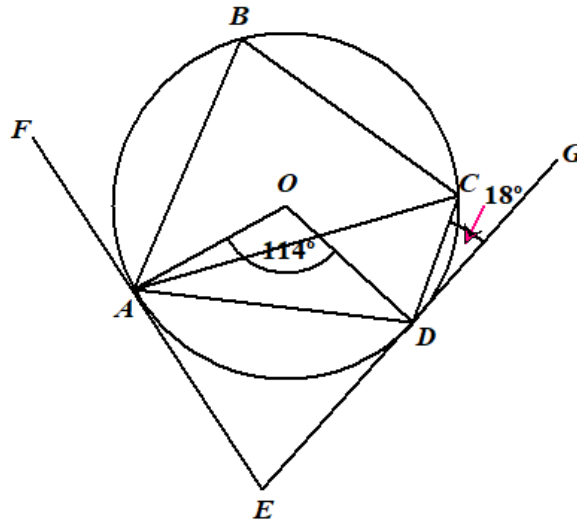

Calculate, giving reasons for EACH step of your answer, the measure of

- (i)  $\hat{ACD}$

**Solution:**

	$\hat{ACD} = \frac{1}{2}(114^\circ) = 57^\circ$ <p>The angle (<math>\hat{AOD} = 114^\circ</math>) subtended by a chord (<math>AD</math>) at the center of a circle (<math>O</math>), is twice the angle that the chord subtends at the circumference, (<math>\hat{ACD}</math>) standing on the same arc.</p>
--	--

(ii)  $\hat{A}ED$

**Solution:**

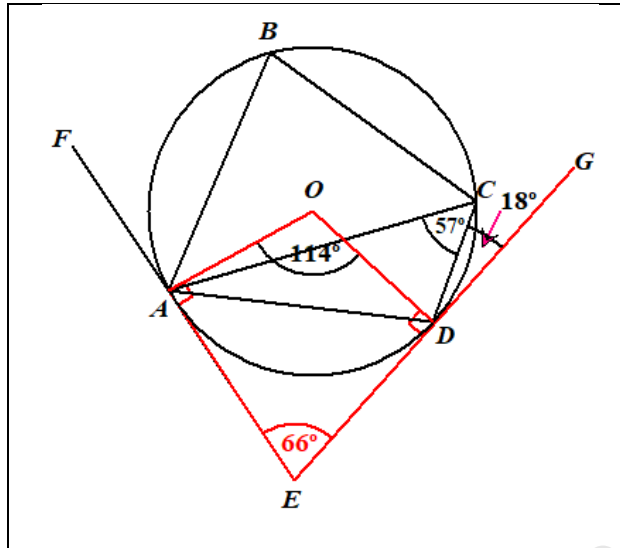

$\hat{O}AE = \hat{O}DE = 90^\circ$   
 The angle between a tangent ( $EA$  and  $ED$ ) to a circle and a radius ( $OA$  and  $OD$ ) at the point of contact  $A$  and  $D$  is a right angle.  
 Consider the quadrilateral  $AODE$ :  
 $\hat{A}ED = 360^\circ - (90^\circ + 114^\circ + 90^\circ) = 66^\circ$   
 The sum of the interior angles of a quadrilateral is  $360^\circ$ .

(iii)  $\hat{O}AC$

**Solution:**

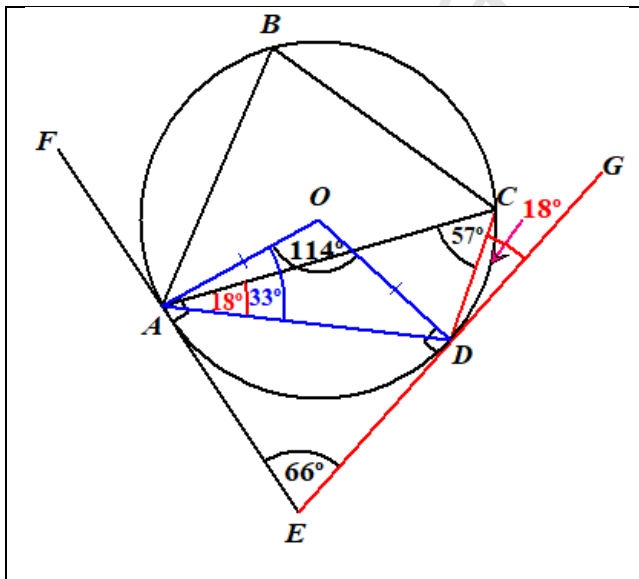

$\hat{C}AD = 18^\circ$   
 The angle between a tangent ( $DG$ ) to a circle and a chord ( $DC$ ) at the point of contact ( $D$ ) is equal to the angle ( $\hat{D}AC$ ) in the alternate segment.  
 $\triangle OAD$  is isosceles,  $OA = OD$  (radii)  
 $\hat{O}AD = \hat{O}DA = \frac{180^\circ - 114^\circ}{2} = 33^\circ$   
 Hence,  $\hat{O}AC = 33^\circ - 18^\circ = 15^\circ$   
 Base angles of an isosceles triangle are equal and the sum of the interior angles in a triangle is  $180^\circ$ .

(iv)  $\hat{A}BC$

**Solution:**

	<p>The angle <math>ADC = 180^\circ - (18^\circ + 57^\circ)</math>  <math>= 105^\circ</math></p> <p>The sum of the interior angles in a triangle is <math>180^\circ</math>.</p> <p>Hence, <math>\hat{A}BC = 180^\circ - 105^\circ = 75^\circ</math></p> <p>The opposite angles of a cyclic quadrilateral are supplementary.</p>
--	--

(b) The diagram below shows a cuboid.

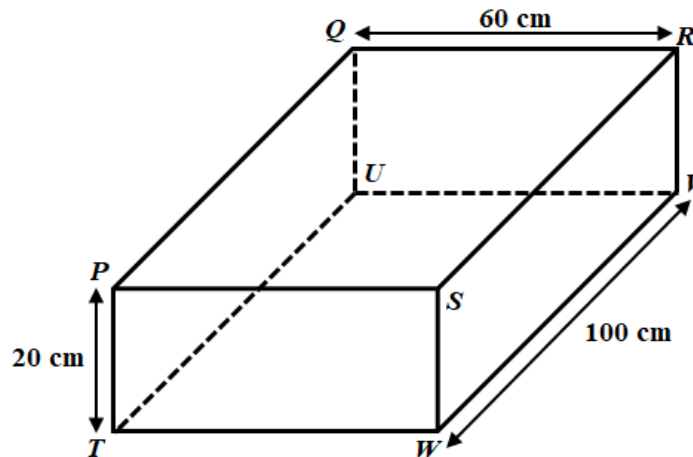

Give your answer correct to 1 decimal place.

- (i) A straight adjustable wire connects  $R$  to  $P$  along the top of the cuboid. Calculate the length of the wire  $RP$ .

**Solution:**

	<p>Consider triangle <math>PRS</math>:</p> $RP^2 = 60^2 + 100^2$ $RP^2 = 13\,600$ $RP = \sqrt{13\,600}$ $RP = 116.61$ $RP = 116.6 \text{ cm correct to 1 dp}$
--	---

- (ii) The connection at  $P$  is now adjusted and moved to  $T$ . Calculate the length of the wire  $RT$ .

**Solution:**

	<p>Consider triangle <math>PRT</math>:</p>
--	--

$$RT^2 = (20)^2 + (\sqrt{13\,600})^2 \quad (\text{Pythagoras' Theorem})$$

$$RT = \sqrt{(\sqrt{13\,600})^2 + (20)^2} = \sqrt{13\,600 + 400} = \sqrt{14\,000}$$

$$= 118.32 \underline{\underline{}} = 118.3 \text{ cm correct to 1 decimal place}$$

(iii) Calculate the angle  $TRV$ .

**Solution:**

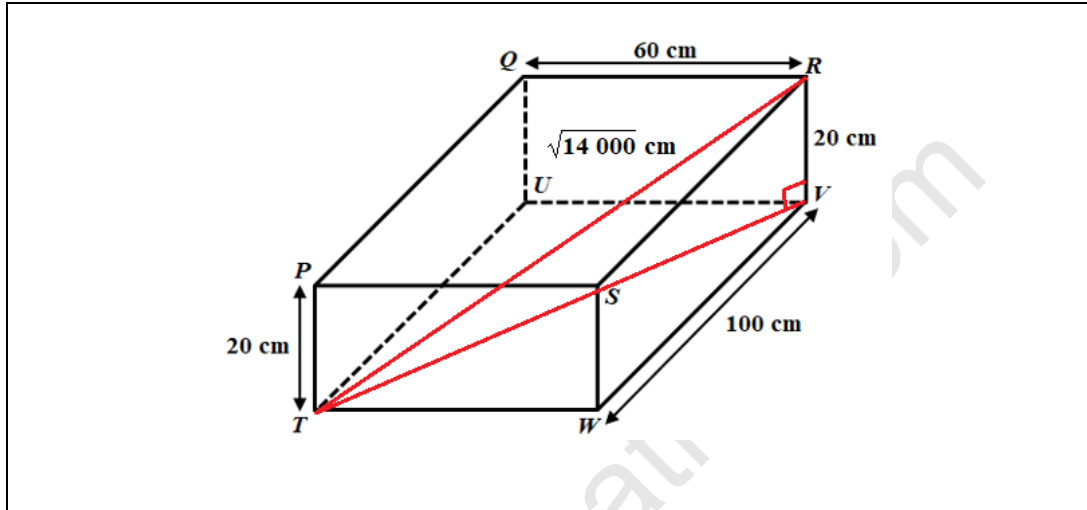

Consider triangle  $TRV$ :

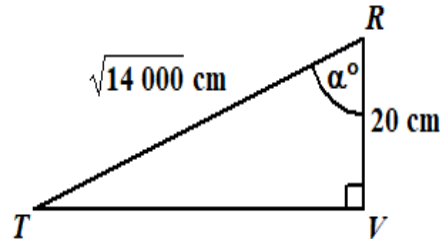

Let  $\hat{TRV} = \alpha^\circ$

$$\cos \alpha = \frac{20}{\sqrt{14\,000}}$$

$$\alpha = \cos^{-1}\left(\frac{20}{\sqrt{14\,000}}\right) = 80.26^\circ = 80.3^\circ \text{ correct to 1 decimal place}$$

(iv) Complete the following statements:

The size of the angle through which the wire moves from  $RP$  to  $RT$  is

.....

An angle which is the same in size as angle  $RTV$  is .....

**Solution:**

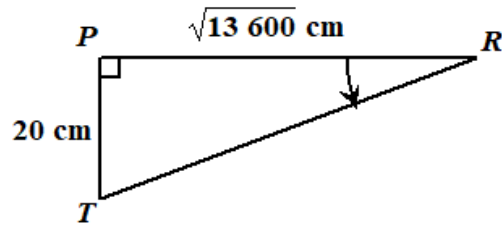

From  $RP$  to  $RT$ , the wire moves through  $\widehat{PRT}$ .

$$\tan \widehat{PRT} = \frac{20}{\sqrt{13\ 600}}$$

$$\widehat{PRT} = \tan^{-1}\left(\frac{20}{118.3}\right) = 9.59^\circ = 9.6^\circ \text{ correct to 1 decimal place}$$

$\widehat{RTV}$  has the same size as  $\widehat{PRT}$  (or  $\widehat{S\hat{U}W}$  or  $\widehat{Q\hat{W}U}$ )

The completed statements are as follows:

The size of the angle through which the wire moves from  $RP$  to  $RT$  is  $9.6^\circ$ .

An angle which is the same in size as angle  $RTV$  is angle  $PRT$  (or angle  $QSU$  or angle  $UWQ$ )

### VECTORS AND MATRICES

11. (a) Given the vectors  $OP = \begin{pmatrix} 3 \\ 4 \end{pmatrix}$ ,  $PQ = \begin{pmatrix} -1 \\ 2 \end{pmatrix}$  and  $RS = \begin{pmatrix} 1 \\ 3 \end{pmatrix}$ ,

(i) determine the vector  $OQ$

$$OP = \begin{pmatrix} 3 \\ 4 \end{pmatrix}$$

$$PQ = \begin{pmatrix} -1 \\ 2 \end{pmatrix}$$

$$RS = \begin{pmatrix} 1 \\ 3 \end{pmatrix}$$



**Solution:**

$$OQ = OP + PQ = \begin{pmatrix} 3 \\ 4 \end{pmatrix} + \begin{pmatrix} -1 \\ 2 \end{pmatrix} = \begin{pmatrix} 2 \\ 6 \end{pmatrix}$$

(ii) show that  $OQ$  is parallel to  $RS$ , giving a reason for your answer.

**Solution:**

$$RS = \begin{pmatrix} 1 \\ 3 \end{pmatrix} = \frac{1}{2} \begin{pmatrix} 2 \\ 6 \end{pmatrix} = \frac{1}{2} OQ$$

Since  $RS$  is a scalar multiple of  $OQ$ , the scalar multiple =  $\frac{1}{2}$ , then  $OQ$  and  $RS$  are parallel.

(b)  $XYZ$  is a triangle and  $M$  is the midpoint of  $XZ$ .  $XY = \mathbf{a}$  and  $YZ = \mathbf{b}$

Express the following vectors in terms of  $\mathbf{a}$  and  $\mathbf{b}$ , simplifying your answers where possible:

(i)  $XZ$  (ii)  $MY$

**Solution:**

We draw a figure to help with the calculations

(i)  $XZ = XY + YZ = \mathbf{a} + \mathbf{b}$

(ii)  $M$  is the mid-point of  $XZ$

$$XM = \frac{1}{2} XZ = \frac{1}{2} (\mathbf{a} + \mathbf{b})$$

$$\therefore MX = - \left\{ \frac{1}{2} (\mathbf{a} + \mathbf{b}) \right\}$$

$$MY = MX + XY = -\frac{1}{2} (\mathbf{a} + \mathbf{b}) + \mathbf{a} = -\frac{1}{2} \mathbf{a} - \frac{1}{2} \mathbf{b} + \mathbf{a} = \frac{1}{2} \mathbf{a} - \frac{1}{2} \mathbf{b}$$

$$= \frac{1}{2} (\mathbf{a} - \mathbf{b})$$

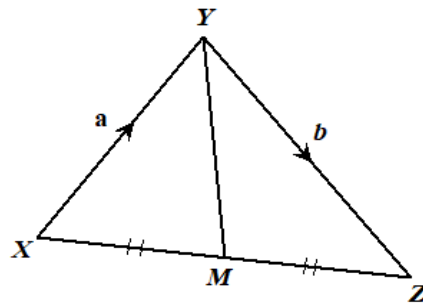

(c) The matrices  $A$  and  $B$  are given as  $A = \begin{pmatrix} -1 & 0 \\ 3 & 2 \end{pmatrix}$  and  $B = \begin{pmatrix} -3 & 2 \\ 1 & 1 \\ 4 & 6 \end{pmatrix}$ .

(i) Determine,  $A^{-1}$ , the inverse of  $A$ .

**Solution:**

$$A = \begin{pmatrix} -1 & 0 \\ 3 & 2 \end{pmatrix}$$

$$\det A = (-1 \times 2) - (0 \times 3) = -2$$

$$\therefore A^{-1} = \frac{1}{-2} \begin{pmatrix} 2 & -(0) \\ -(3) & -1 \end{pmatrix} = \begin{pmatrix} \frac{2}{-2} & \frac{0}{-2} \\ \frac{-3}{-2} & \frac{-1}{-2} \end{pmatrix} = \begin{pmatrix} -1 & 0 \\ \frac{3}{2} & \frac{1}{2} \end{pmatrix}$$

(ii) Show that  $A^{-1}A = I$ , the identity matrix.

**Solution:**

$$A^{-1}A = \begin{pmatrix} -1 & 0 \\ \frac{3}{2} & \frac{1}{2} \end{pmatrix} \begin{pmatrix} -1 & 0 \\ 3 & 2 \end{pmatrix} = \begin{pmatrix} e_{11} & e_{12} \\ e_{21} & e_{22} \end{pmatrix}$$

$$2 \times 2 = 2 \times 2 \times 2 \times 2$$

$$e_{11} = (-1 \times -1) + (0 \times 3) = 1$$

$$e_{12} = (-1 \times 0) + (0 \times 2) = 0$$

$$e_{21} = \left(\frac{3}{2} \times -1\right) + \left(\frac{1}{2} \times 3\right) = -\frac{3}{2} + \frac{3}{2} = 0$$

$$e_{22} = \left(\frac{3}{2} \times 0\right) + \left(\frac{1}{2} \times 2\right) = 1$$

$$\therefore A^{-1}A = \begin{pmatrix} 1 & 0 \\ 0 & 1 \end{pmatrix}$$

**QED**

(iii) Determine the matrix  $A^2$ .

**Solution:**

$$A^2 = A \times A = \begin{pmatrix} -1 & 0 \\ 3 & 2 \end{pmatrix} \begin{pmatrix} -1 & 0 \\ 3 & 2 \end{pmatrix} = \begin{pmatrix} e_{11} & e_{12} \\ e_{21} & e_{22} \end{pmatrix}$$

$$2 \times 2 = \quad \quad \quad 2 \times 2 \times \quad 2 \times 2$$

$$e_{11} = (-1 \times -1) + (0 \times 3) = 1$$

$$e_{12} = (-1 \times 0) + (0 \times 2) = 0$$

$$e_{21} = (3 \times -1) + (2 \times 3) = 3$$

$$e_{22} = (3 \times 0) + (2 \times 2) = 4$$

$$\therefore A^2 = \begin{pmatrix} 1 & 0 \\ 3 & 4 \end{pmatrix}$$

(iv) a) Explain why the matrix product  $AB$  is not possible.

**Solution:**

$$\begin{array}{cc} A & \times & B \\ 2 \times 2 & & 3 \times 2 \\ & \neq & \end{array}$$

The number of columns of  $A$  which is 2 is not equal to the number of rows of  $B$  which is 3. These must be equal for matrices to be conformable to multiplication. In this case they are not. Hence, the product  $AB$  is not possible.

b) Without calculating, state the order of the matrix product  $BA$ .

**Solution:**

$$\begin{array}{ccc} BA = B & \times & A \\ 3 \times 2 & \times & 2 \times 2 \\ & = & 3 \times 2 \end{array}$$

The number of columns of  $B$  which is 2 is equal to the number of rows of  $A$  which is 2. These must be equal for matrices to be conformable to multiplication. In this case they are. Hence, the product  $BA$  is possible. The order of the result will be No. of rows of  $B \times$  No. of columns of  $A$ . So, the product  $BA$  is possible and would give a  $3 \times 2$  matrix if it were to be done.